

C10 MODULE

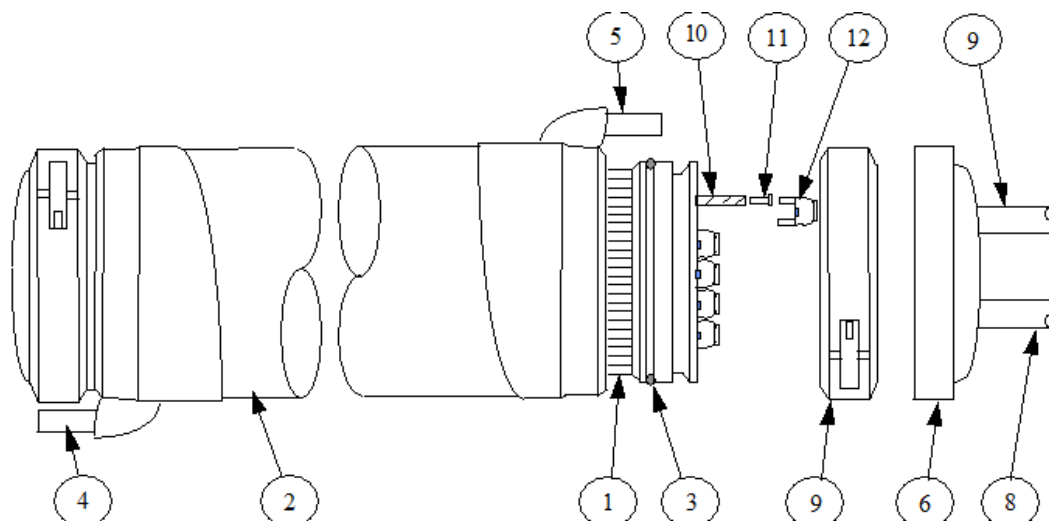

C10 UF MODULE ASSEMBLY

The C10 ultrafiltration system offers the user a low cost tubular module, which can be fitted with a wide range of replacable membrane elements.

Each C10 UF module contains 10.5m² of membrane area and the modular design enables plant of any size to be quickly and easily constructed. A range of end cap designs permits different membrane path lengths and cross flow permutations to be utilised.

The plastic construction of the C10 module keeps cost to a minimum, while maintaining all the benefits of a tubular system. Cleaning of the membrane elements can be mechanical with the use of foam balls or chemical using CIP techniques. The C10 module and the proven CA202 membrane carry DWI Regulation approval.

C10 Parts List

Item	Description	No. Off
1	Tube nest	1
2	Module shroud	1
3	Shroud O-ring seal	2
4	Permeate drain	1
5	Permeate outlet	1
6	End cap	2
7	Retaining clamp	2
8	Module inlet connection	1
9	Module outlet connection	1
10	Membrane tube	72
11	Tube-seal	144
12	U-bend / Insert	72

C10 MODULE

Operating Limits	
Maximum operating pressures	12 bar
Maximum operating temperature:	30°C
C10 Membrane area	10.4 m ²
Overall module length	3.8 m
Module diameter	0.21 m (tube)
Weights	
Weight empty	48.5 kg
Weight full with water	137 kg
Liquid volumes	
Hold-up volume - tube side	35 litres
Hold-up volume - shroud side	54 litres
Connections	
Module inlet	¾" or 1" ABS union
Module outlet	¾" or 1" ABS union
Permeate off-takes	¾" or 1" ABS union

Note:

The above limits are for the module only. Other limiting factors will be determined by the membrane type being used.

Operating information

The graph shows the expected pressure drop for one C10 module.

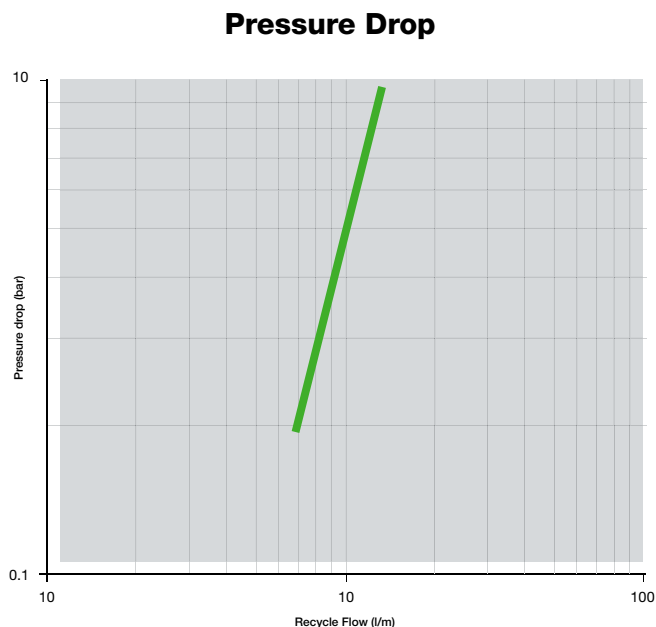

Important:

Because of the long path length in the C10 module, the pressure drop is very flux dependent. The data used to compile this graph was taken with membrane fluxes in the range of 10 - 30 l/m²hr.